

TED (21) -1005 A
(Revision- 2021)

2102220009 A

Reg.No.....
Signature.

DIPLOMA EXAMINATION IN ENGINEERING/TECHNOLOGY/MANAGEMENT/
COMMERCIAL PRACTICE –NOVEMBER -2021.

ENGINEERING GRAPHICS

(Maximum Marks : 75)

[Time : 3 hours]

- [Note:- 1. A2 size drawing sheet to be supplied.
2. Missing data if any suitably assumed.
3. Sketches are accompanied.
4. Dimension as per BIS.
5. All drawing should be in first angle projections.]

PART–A

Marks

I. Answer **all** the following questions in one word or sentence or sketch.

(5x1 = 5 Marks)

Module Outcome Cognitive level

		Module Outcome	Cognitive level
1	Draw the following types of lines (a) Continuous thin (straight) with zig-zags. (b) Chain thin line.	M1.02	U
2	List any two types of conic sections.	M1.04	U
3	The view obtained on the horizontal plane is called.....	M2.01	U
4	Draw the symbol of third angle projection.	M3.01	U
5	Give the command used in Auto CAD to draw a straight line or series of line segment.	M4.04	A

PART - B

II Answer **any Five** of the following questions . Each question carries 8 marks.

(5x8=40 Marks)

Module Outcome Cognitive level

		Module Outcome	Cognitive level
1	Using simple sketches show (a) Chain dimensioning. (b) Parallel dimensioning. (c) Co-ordinate dimensioning.	M1.03	U
2	Draw a regular hexagon of 40 mm side.	M1.04	U
3	Draw an Ellipse by rectangular method, major and minor axes given as 150 mm and 90 mm respectively.	M1.04	U
4	Draw an involute of a regular pentagon 30 mm side.	M1.04	U

5	Draw the projections of the following points on a common reference line keeping the distance between the projections as 40 mm. (a) Point A is 40 mm above H.P. and 30 mm in front of V.P. (b) Point B is in the V.P. and 40 mm below H.P. (c) Point C is 35 mm below H.P. and 50 mm behind V.P.	M2.02	U
6	A straight-line AB 70 mm long is parallel to both H.P. and V.P. The point A is 30 mm above H.P. and 40 mm in front of V.P. Draw its projections.	M2.03	A
7	The length of the top view of a line PQ which is parallel to V.P. and inclined at 45° to H.P is 60 mm. One end of the line is 20 mm above H.P. and 30 mm in front of V.P. Draw the projections of the line and determine its true length.	M2.03	A

PART - C

III. Answer **any two** questions. Each question carries 15 marks.

(2 x 15 = 30 Marks)

		Module Outcome	Cognitive level
1	Oblique view of an open bearing is shown in figure 1. Draw and dimension the front view in the direction of the arrow F and right-side views in the direction of the arrow R.	M3.01	U
2	Figure-2 shows isometric view of a shaft support. Draw and dimension the following views: (a) Full sectional front view in the direction of the arrow F. (b) Top view in the direction of arrow T.	M3.02	A
3	Orthographic views of a block are shown in figure 3. Draw the isometric view of the object and dimension it.	M4.02	A

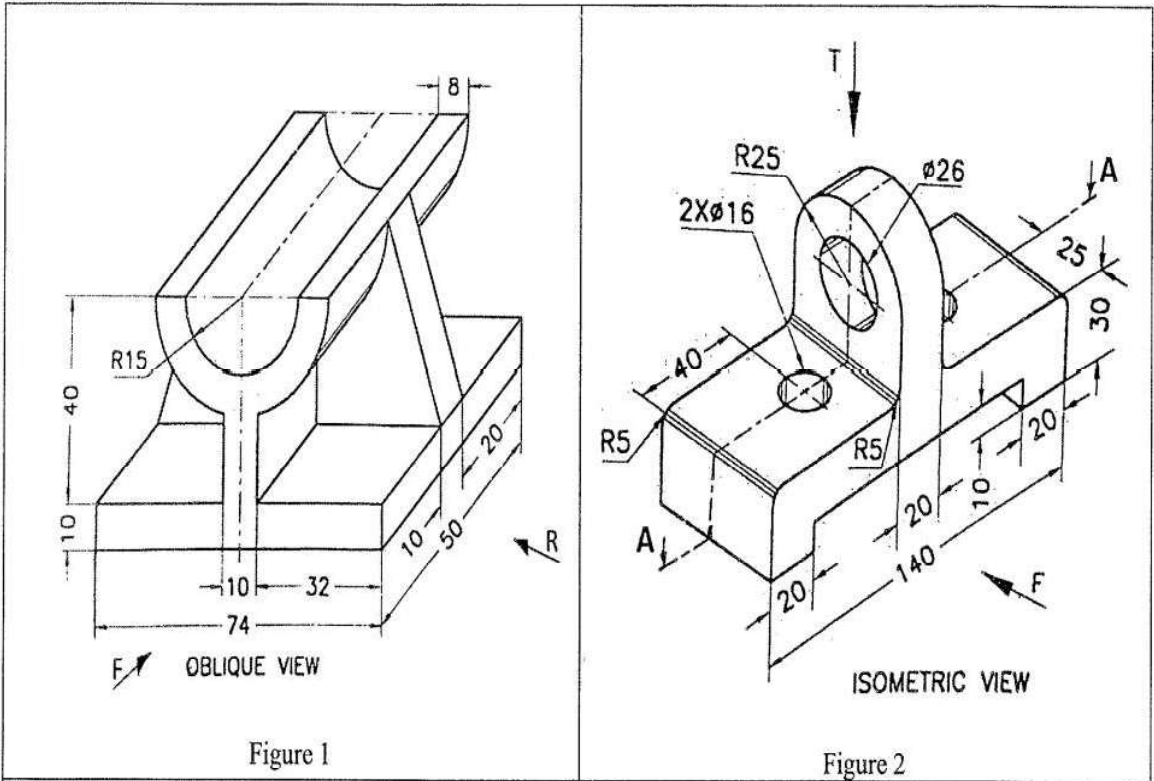

Figure 1

Figure 2

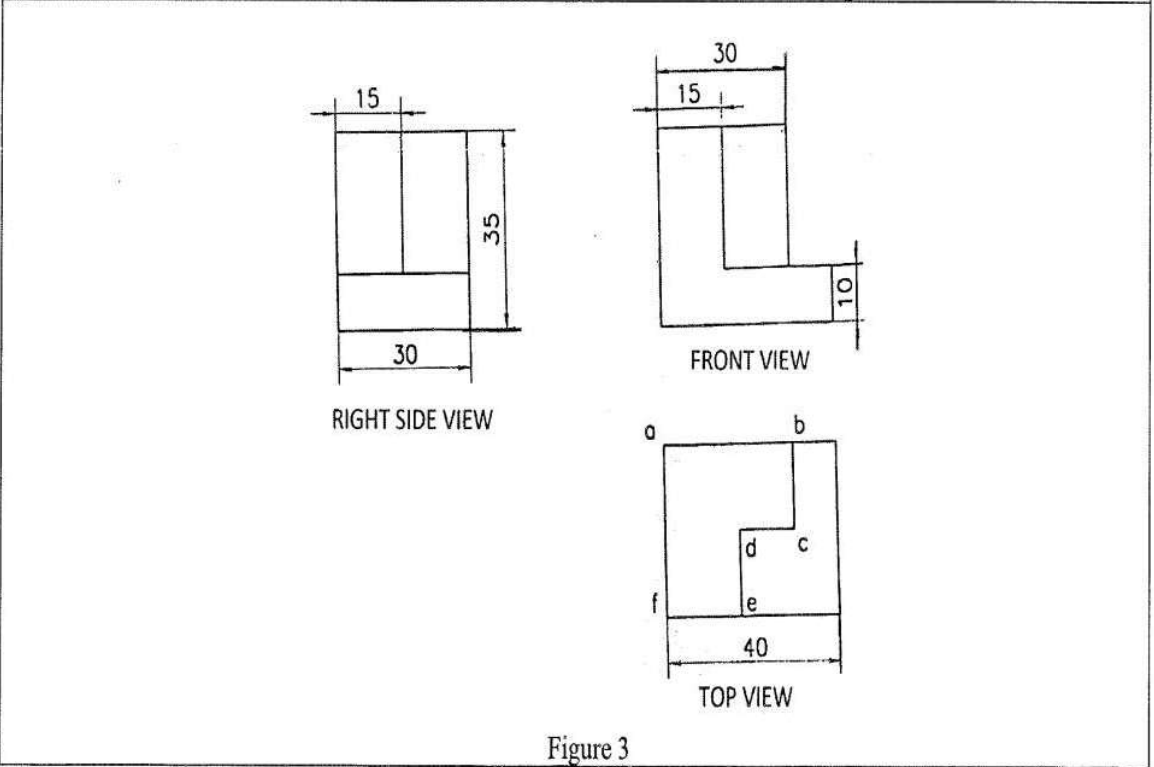

Figure 3

TED (21) -1005 B
(Revision- 2021)

2102220009 B

Reg.No.....
Signature.

DIPLOMA EXAMINATION IN ENGINEERING/TECHNOLOGY/MANAGEMENT/
COMMERCIAL PRACTICE –NOVEMBER -2021.

ENGINEERING GRAPHICS

(Maximum Marks : 75)

[Time : 3 hours]

- [Note:- 1. A2 size drawing sheet to be supplied.
2. Missing data if any suitably assumed.
3. Sketches are accompanied.
4. Dimension as per BIS.
5. All drawing should be in first angle projections.]

PART–A

Marks

I. Answer **all** the following questions in one word or sentence or sketch.

(5x1 = 5 Marks)

		Module Outcome	Cognitive level
1	Give the sizes of two commonly used types of set squares.	M1.02	U
2	List any three types of scales.	M1.05	U
3	The view obtained on the vertical plane is called	M2.01	U
4	Mention any two important full sectional views of an object.	M3.02	A
5	Identify any two applications of CAD.	M4.04	A

PART - B

II Answer **any Five** of the following questions . Each question carries 8 marks.

(5x8=40 Marks)

		Module Outcome	Cognitive level
1	Show different elements of dimensioning with the help of a simple sketches.	M1.03	U
2	Draw a regular heptagon of side 50 mm.	M1.04	U
3	Draw a Parabola when the distance of focus from the directrix is 8 cm.	M1.04	U
4	Draw an involute of an equilateral triangle of 40 mm side.	M1.04	U

5	Draw the projections of the following points on a common reference line: (a) Point A is 30 mm above H.P. and 20 mm in front of C.P. (b) Point B is 30 below H.P. and 20 mm behind V.P. (c) Point C is 40 mm above H.P. and 20 mm behind V.P.	M2.02	U
6	Draw the projections of a line AB, 90 mm long, inclined at 35 degrees to H.P. and parallel to V.P. The line is 45 mm in front of V.P. The lower end A, is 25mm above H.P.	M2.03	A
7	The length of the elevation of a line GH which is parallel to H.P. and inclined at 30° to V.P. is 50 mm. The end G of the line is 15 mm in front of V.P. and 25 mm above H.P. Draw the projections of the line and find its true length.	M2.03	A

PART - C

III. Answer **any two** questions. Each question carries 15 marks.

(2 x 15 = 30 Marks)

		Module Outcome	Cognitive level
1	Isometric view of an object is shown in figure- 1. Draw and dimension the (a) Front view in the direction of arrow F. (b) Top view in the direction of arrow T.	M3.01	U
2	Figure-2 shows pictorial views of an object. Draw and dimension the following views: (a) Full sectional front view in the direction of the arrow F. (b) Top view.	M3.02	A
3	Orthographic views of an object are shown in figure- 3. Draw the isometric view of the object and dimension it.	M4.02	A

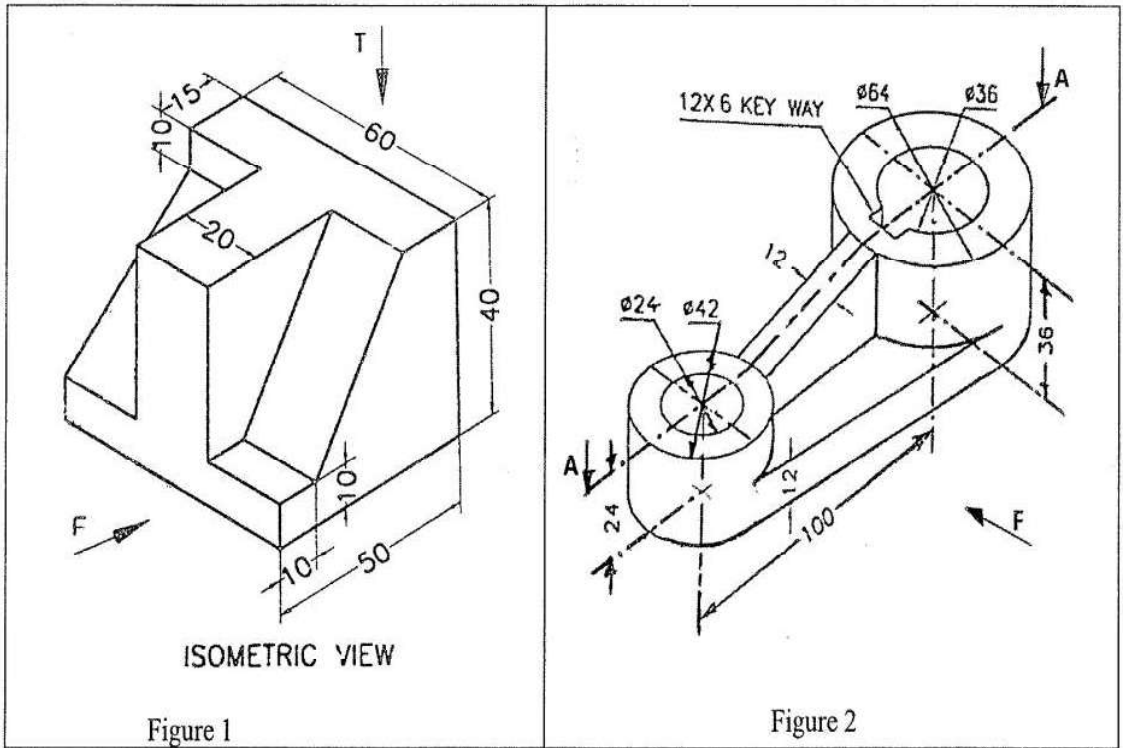

Figure 1

Figure 2

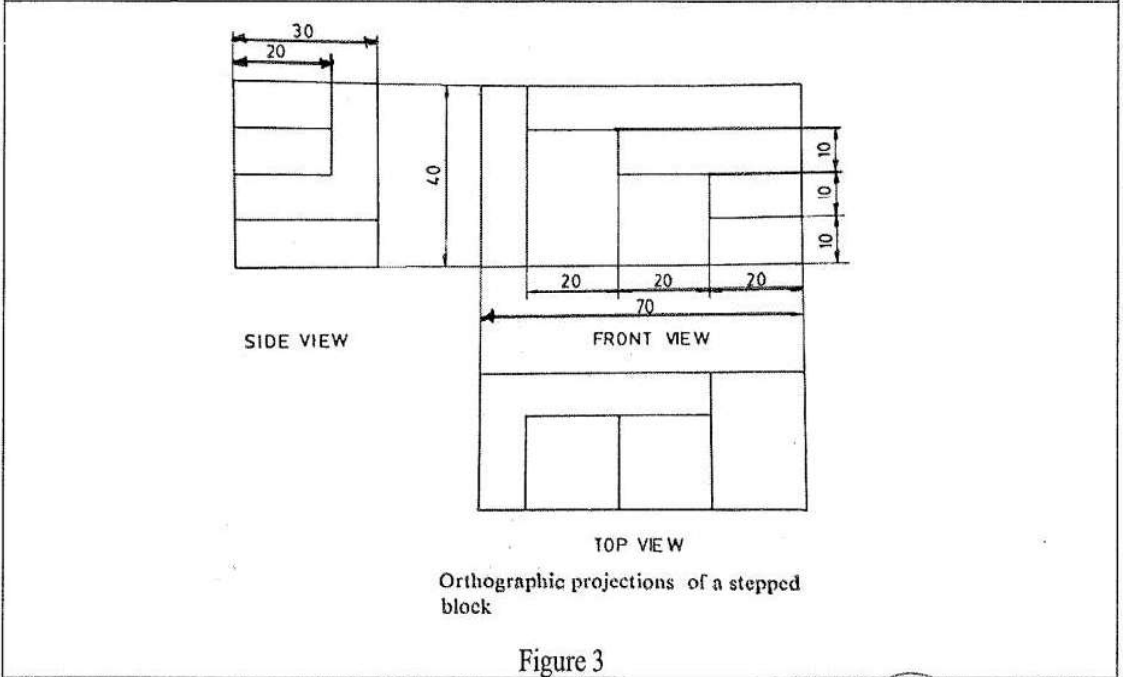

Figure 3
